

# STI Universal Stopper<sup>®</sup>



## KEY FEATURES

### General Information

- These indoor and outdoor low profile or dome polycarbonate covers can protect a variety of devices without restricting legitimate operation.
- Three year guarantee against breakage of polycarbonate in normal use (one year on electromechanical and electronic components).

### Design

- Prevents false alarms, without hindering legitimate operation of a manual call point in the event of an emergency.

### Construction

- Tough polycarbonate housing can withstand severest of knocks.

### Installation

- A simple 4 fixing installation can retrofit over existing device.
- Can accommodate flush or surface mount applications.
- Typical working properties of polycarbonate are -40° to 121°C (-40° to 250°F).

### Electronics

- Available with or without a 96 dB integral sounder, powered by a 9V PP3 battery. The sounder draws immediate attention to the area.
- Optional 12-24 VDC powered units.

### Options

- One breakseal is supplied with each model. Additional breakseals are available for added security.
- Available in a range of colours.
- Custom labelling available.

## PRODUCT OVERVIEW

These indoor and outdoor low profile or dome polycarbonate covers protect devices such as manual call points, emergency buttons and dual action pull stations etc., without restricting legitimate operation. The versatile cover offers excellent protection against physical damage (both accidental and intentional), dust and grime as well as severe environments inside and out.

## IMPORTANT NOTICE

When used on fire systems, Universal Stopper is intended for areas where the incidence of false fire alarms from manual call points is high or has proven to be a serious problem. Any disadvantage of the device is more than balanced when one considers the consequences of false fire alarms, especially if fire service personnel and equipment are responding to a false fire alarm when they are needed for a real fire somewhere else. Add to this the disruption to the facility when false alarms occur. If you have, or may have, a problem with false fire alarms or physical/weather damage to your fire alarm activation devices, the Universal Stopper could prove invaluable.

# STI Universal Stopper®

Dimensions and Technical Information

## BUILD YOUR OWN MODEL



### Cover Options:

- 3 = Dome cover
- 4 = Low profile cover (only available with hood/horn option '00')

### Mounting Options:

- 0 = Flush Mount (Open backed)
- 1 = Surface Mount - Clear Spacer (Dual Mount - Open backed)
- 2 = Surface Mount - Hinged Coloured (Open backed) Spacer
- 3 = Enclosed Flush Back Box
- 4 = US Enclosed Back Box, 3/4 NPT Thread Point & Sealed Mounting Plate
- 5 = US Enclosed Back Box, 3/4 NPT Thread Point & Open Mounting Plate
- 6 = European Enclosed Back Box, 20mm Thread Point & Sealed Mounting Plate
- 7 = European Enclosed Back Box, 20mm Thread Point & Open Mounting Plate
- 8 = US Enclosed Back Box, 3/4 NPT Thread Point & European Sealed Mounting Plate
- 9 = US Enclosed Back Box, 3/4 NPT Thread Point & European Open Mounting Plate
- A = European Enclosed Back Box, 20mm Thread Point & US Sealed Mounting Plate
- B = European Enclosed Back Box, 20mm Thread Point & US Open Mounting Plate

**NB: Options 2, 4, 5, 8, 9, A & B are special orders and would acquire longer lead times**

### Hood/Horn Options:

- 00 = No Label hood (Label option must be NC)
- 10 = Label hood without sounder\*\*
- 20 = Label hood with sounder\*\*
- 30 = Label hood with sounder and relay\*\*

\*\* All colours except NC

### Housing/Sounder Colour & Label Options:

FR = Red - Fire Label

EG = Green - Emergency Exit Label

#### No Label

- NK = Black
- NB = Blue
- NC = Clear
- NG = Green
- NR = Red
- NW = White
- NY = Yellow

#### Custom Label

- CK = Black
- CB = Blue
- CG = Green
- CR = Red
- CW = White
- CY = Yellow

For custom label option, must provide wording (2 lines, 30 characters per line including spaces limit)

## EXTERNAL DIMENSIONS (mm):

Mounting Option	Height	Width	Depth
Flush	207	137	68
Surface	207	137	105
Enclosed Flush Back Box	207	137	71
Enclosed Back Box	207	137	102

## APPROVALS

TESTED AND APPROVED OR LISTED BY:

· UL/cUL Listed No. S2466

(NEMA Type 3RX mounting options 3, 4, 5, 8, 9)

### Back box with opened mounting plate

- IP rating 56 (cover 3, mounting options 4, 5, 8, 9)

### Back box with sealed mounting plate

- IP rating 66

## MODELS AVAILABLE

**STI-13010-FR** Universal Stopper, (flush mounted, dome cover with open back) without sounder, with fire label

**STI-13120-EG** Universal Stopper, (surface mounted, dome cover with open back) with sounder, with emergency exit label

**PLEASE REFER TO BUILD YOUR OWN MODEL TO GENERATE OVER 500 VARIATIONS OF THIS PRODUCT**

### ACCESSORIES:

- STI-1331** 37mm Spacer
- KIT-319** Remote Wiring Harness for Remote Power
- KIT-EA135** Servicing Pin
- STI-1314** Universal Stopper Backplate
- CKS001** Replacement Sounder Unit
- STI/BS** Break Seals (Quantity: 10)
- CKS006** Replacement Housing Shell (Red)  
Add -G for Green, -B for Blue, -Y for Yellow, -K for Black, -W for White

### NB:

- Red Fire Label: 'In Case of Fire - Lift Cover Break Glass'
- Green Emergency Exit Label: 'In Case of Emergency - Lift Cover Break Glass to open Door'
- European Enclosed Back Box = Clear Frosted
- US Enclosed Back Box = Coloured

## DIMENSIONS:

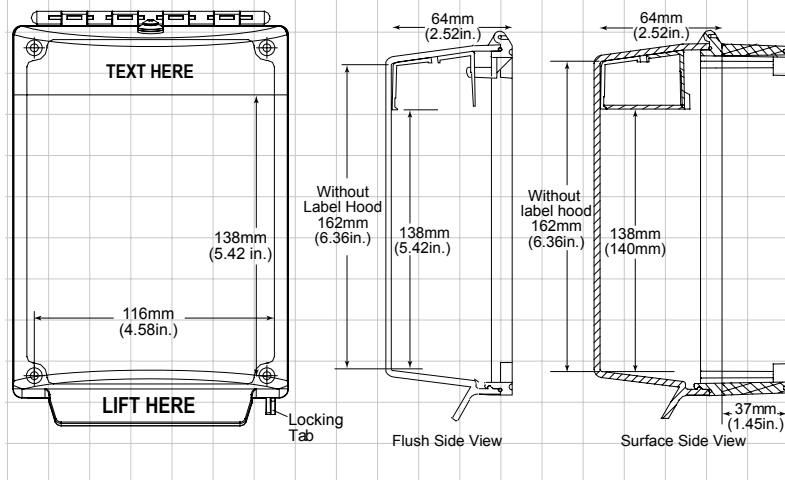
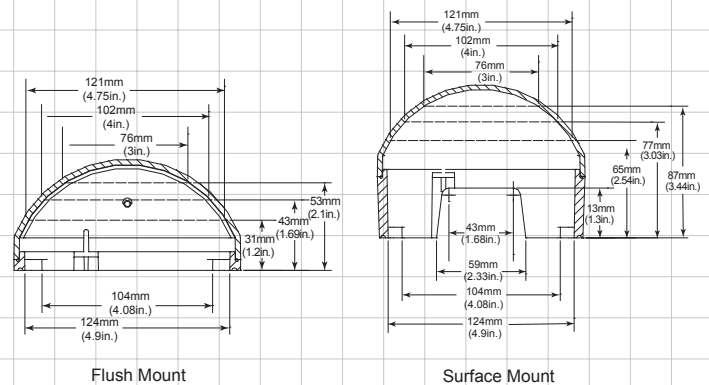

**Safety Technology International**

Taylor House  
34 Sherwood Road  
Bromsgrove  
Worcestershire  
B60 3DR, England

Tel: +44 (0)1527 520 999  
Fax: +44 (0)1527 501 999  
info@sti-emea.com  
www.sti-emea.com

2306 Airport Road  
Waterford, Michigan  
48327, USA

Tel: 248-673-9898  
Fax: 248-673-1246  
Toll-free: 0800-888-4784  
info@sti-usa.com  
www.sti-usa.com